

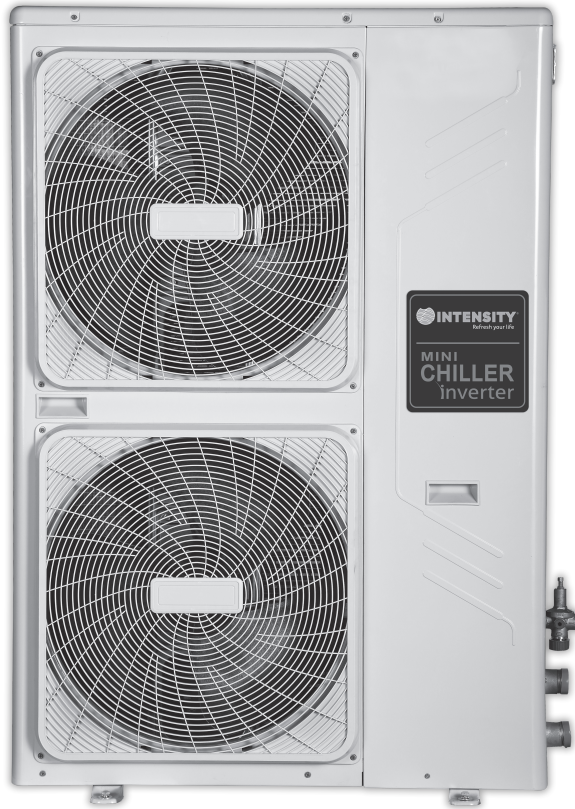

INTENSITY[®]

Refresh your life



MINI CHILLER inverter
3 and 5 Tons.

IMCH-036KC-3 / IMCH-060KC-3

INSTALLATION & OWNER'S MANUAL



intensity.mx



MAN-IO-IMCH-0615

CONTENTS

PAGE

PRECAUTIONS.....	1
ATTACHED FITTINGS.....	2
MAIN PARTS OF THE UNIT.....	2
REFRIGERANT CYCLE.....	3
UNIT INSTALLATION.....	3
WATER PIPE INSTALLATION.....	5
RECOMMENDED OPERATING AREA.....	7
HYDRAULIC DATA.....	8
ELECTRICAL CONNECTIONS.....	9
THE HOST UNIT CONTROLLER ELUCIDATION.....	11
MAIN PARAMETERS.....	15

1. PRECAUTIONS

To prevent injury to the user or other people and property damage, the following instructions must be followed. Incorrect operation due to ignoring of instructions may cause harm or damage.

The safety precautions listed here are divided into two categories. In either case, important safety information is listed which must be read carefully.

 **WARNING**
Failure to observe a warning may result in death.

 **CAUTION**
Failure to observe a caution may result injury or damage to the equipment.

 **WARNING**

- **Ask your dealer for installation of the air conditioner.**
Incomplete installation performed by yourself may result in a water leakage, electric shock, and fire.
- **Ask your dealer for improvement, repair, and maintenance.**
Incomplete improvement, repair, and maintenance may result in a water leakage, electric shock, and fire.
- **In order to avoid electric shock, fire or injury, or if you detect any abnormality such as smell of fire, turn off the power supply and call your dealer for instructions.**
- **Never replace a fuse with that of wrong rated current or other wires when a fuse blows out.**
Use of wire or copper wire may cause the unit to break down or cause a fire.
- **Do not insert fingers, rods or other objects into the air inlet or outlet.**
When the fan is rotating at high speed, it will cause injury.
- **Never use a flammable spray such as hair spray, lacquer or paint near the unit.**
It may cause a fire.
- If the supply cord is damaged, it must be replaced by the manufacturer, its service agent or similarly qualified persons in order to avoid a hazard.





- **Never inspect or service the unit by yourself.**
Ask a qualified service person to perform this work.
- **Do not dispose this product as unsorted municipal waste. Collection of such waste separately for special treatment is necessary.**
- **Keep far away from high-frequency equipment.**
- **Keep away from the following places:**
a place where it is full of oil gas; places where salty air surrounding(near the coast); a place where is caustic gas(the sulfide in hotspring). Location in the folling places may cause malfunction or shorten the life span of the manchine.
- **In the cace of extremely strong wind, please prevent the air from flowing backwards into the outdoor unit.**
- **Snow canopy is necessary in sonwfall places on the outdoor unit. Please consult the local dealer for details.**
- **In the frequent thunderstruck place, lightning proof actions should be taken.**
- **To prevent refrigerant leak, contact your dealer.**
When the system is installed and runs in a small room, it is required to keep the concentration of the refrigerant, if by any chance coming out, below the limit. Otherwise, oxygen in the room may be affected, resulting in a serious accident.
- **The refrigerant in the air conditioner is safe and normally does not leak.**
If the refrigerant leaks in the room, contact with a fire of a burner, a heater or a cooker may result in a harmful gas.
- **Turn off any combustibile heating devices, ventilate the room, and contact the dealer where you purchased the unit.**
Do not use the air conditioner until a service person confirms that the portion where the refrigerant leaks is repaired.
- This appliance can be used by children aged from 8 years and above and persons with reduced physical, sensory or mental capabilities or lack of experience and knowledge if they have been given supervision or instruction concerning use of the appliance in a safe way and understand the hazards involved. Children shall not play with the appliance. Cleaning and user maintenance shall not be made by children without supervision.

 **CAUTION**

- **Do not use the air conditioner for other purposes.**
In order to avoid any quality deterioration, do not use the unit for cooling precision instruments, food, plants, animals or works of art.
- **Before cleaning, be sure to stop the operation, turn the breaker off or pull out the supply cord.**
Otherwise, an electric shock and injury may result.
- **In order to avoid electric shock or fire, make sure that an earth leak detector is installed.**
- **Be sure the air conditioner is grounded.**
In order to avoid electric shock, make sure that the unit is grounded and that the earth wire is not connected to gas or water pipe, lightning conductor or telephone earth wire.
- **In order to avoid injury, do not remove the fan guard of the outdoor unit.**
- **Do not operate the air conditioner with a wet hand.**
An electric shock may happen.
- **Do not touch the heat exchanger fins.**
These fins are sharp and could result in cutting injuries.

- **After a long use, check the unit stand and fitting for damage.**
If damaged, the unit may fall and result in injury.
- **To avoid oxygen deficiency, ventilate the room sufficiently if equipment with burner is used together with the air conditioner.**
- **Arrange the drain hose to ensure smooth drainage.**
Incomplete drainage may cause wetting of the building, furniture etc.
- **Never expose little children, plants or animals directly to the air flow.**
Adverse influence to little children, animals and plants may result.
- **Notice to avoid places where operation noise may easily be spread away or be enhanced.**
- **Noise can be amplified by anything blocking the air outlet of outdoor unit.**
- Choose a proper place that the noise and hot or cold wind blown out of the outdoor unit will not bring inconvenience to your neighbors and not affect the growth or animal or plant.
- Recommending locate and operate the equipment at the altitude height not exceed than 1000m.
- Endurable temperature during transportation is -25 ~55 .
Such equipment could endure 70 of the maximum temperature in 24hrs.
- Do not allow a child to mount on the outdoor unit or avoid placing any object on it.
Falling or tumbling may result in injury.
- Do not operate the air conditioner when using a room fumigation - type insecticide.
Failure to observe could cause the chemicals to become deposited in the unit, which could endanger the health of those who are hypersensitive to chemicals.
- Do not place appliances which produce open fire in places exposed to the air flow from the unit or under the indoor unit.
It may cause incomplete combustion or deformation of the unit due to the heat.
- Do not install the air conditioner at any place where flammable gas may leak out.
If the gas leaks out and stays around the air conditioner, a fire may break out.
- The appliance is not intended for use by young children or infirm persons without supervision.
- Young children should be supervised to ensure that they do not play with the appliance.
- Stationary appliances not fitted with means for disconnection from the supply mains having a contact separation in all poles that provide full disconnection under overvoltage category III, the instructions state that means for disconnection must be incorporated in the fixed wiring in accordance with the wiring rules.

2. ATTACHED FITTINGS

Unit	Installation & Owner's Manual	Rubber ring for wires	Outflow connecting tube	Straight screwdriver
Qty.	1	2	1	1
Shape.				

3. MAIN PARTS OF THE UNIT

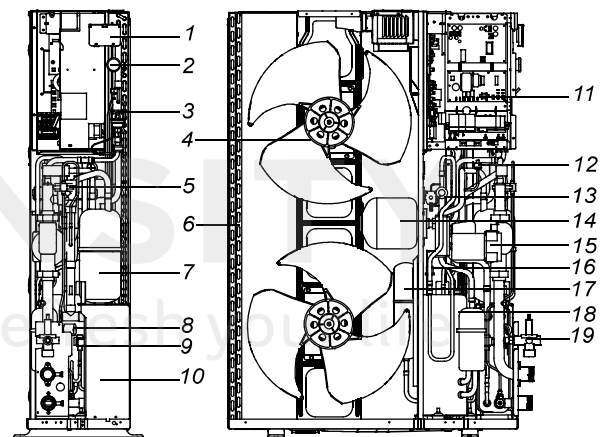

Fig.3-1

- | | |
|--------------------------------|-------------------------|
| 1 Operation panel | 11 Electrical panel |
| 2 Water manometer | 12 High pressure switch |
| 3 Automatic discharge valve | 13 4-ways valve |
| 4 Axial-flow fan | 14 Expansion tank |
| 5 Differential pressure switch | 15 Pump |
| 6 Condenser | 16 Low pressure switch |
| 7 Accumulator | 17 Storage tank |
| 8 Security discharge | 18 Compressor |
| 9 Electric expansive valve | 19 Water supply valve |
| 10 Plate heat exchanger | |

4. REFRIGERANT CYCLE

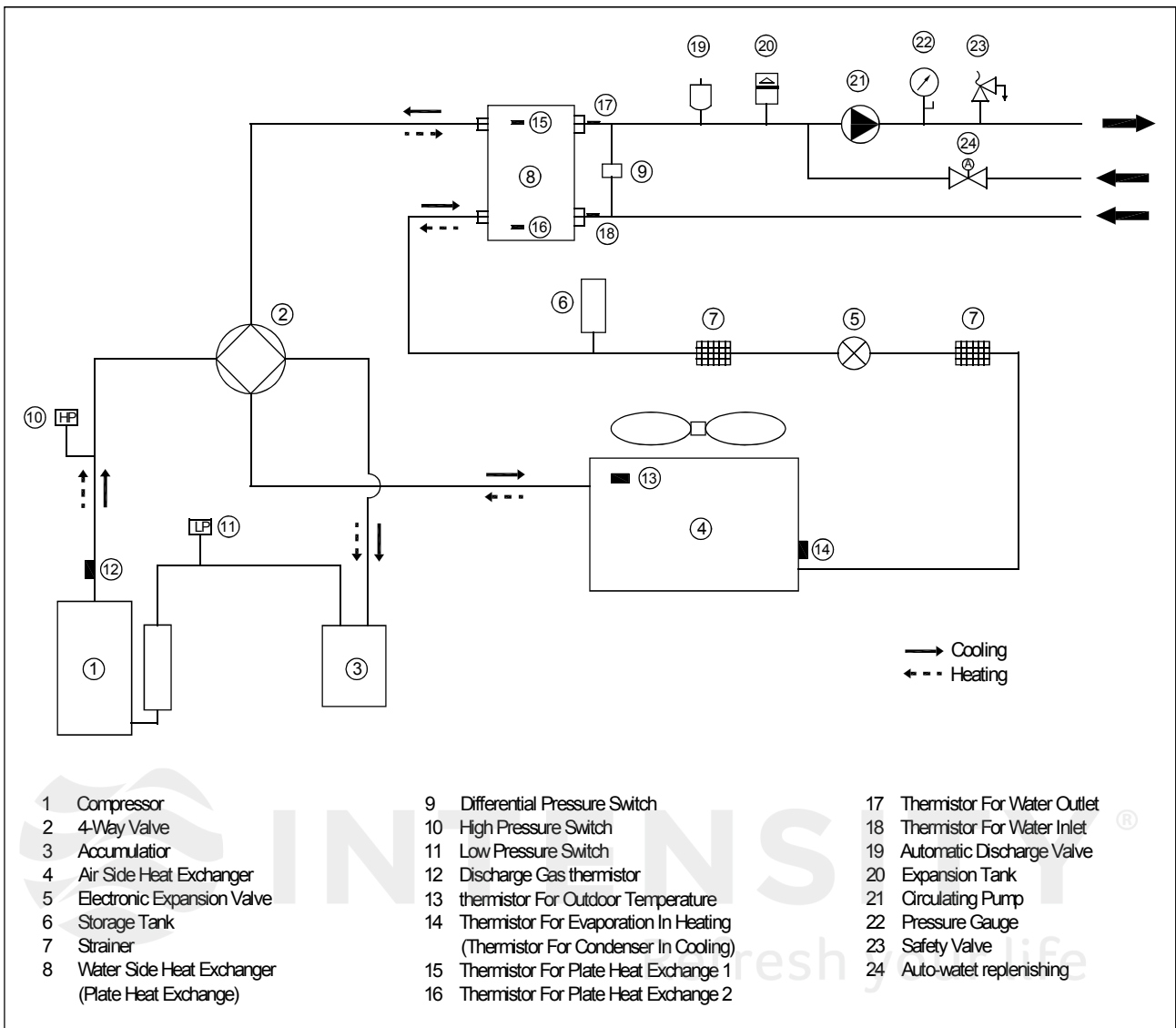

Fig. 4-1

5. UNIT INSTALLATION

5.1 Installation place

Please keep away from the following place, or malfunction of the machine may be caused:

- There is combustible gas leakage.
- There is much oil (including engine oil) ingredient.
- There is salty air surrounding (near the coast)
- There is caustic gas (the sulfide, for example) existing in the air (near a hot spring)
- A place the heat air expelled out from the outdoor unit can reach your neighbor's window.
- A place that the noise interferes your neighbors every day life.
- A place that is too weak to bear the weight of the unit
- Uneven place.
- Insufficient ventilation place.
- Near a private power station or high Frequency equipment.

- Install indoor unit, outdoor unit, power cord and connecting wire at least 1m away from TV set or radio to prevent noise or picture interference.

The insulation of the metal parts of the building and the air conditioner should comply with the regulation of National Electric Standard.



CAUTION

Keep indoor unit, outdoor unit, power supply wiring and transmission wiring at least 1 meter away from televisions and radios. This is to prevent image interference and noise in those electrical appliances. (Noise may be generated depending on the conditions under which the electric wave is generated, even if 1 meter is kept.)

5.2 Installation space (Unit:mm)

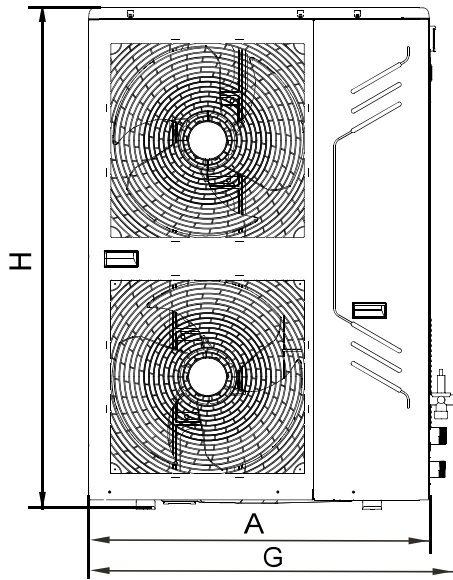

Fig.5-1

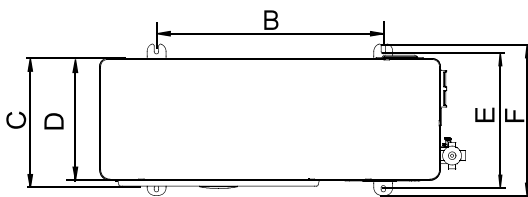

Fig.5-2

table 5-1~unit :mm~

MODEL (KBTUS/hr)	A	B	C	D	E	F	G	H	Fig
36 / 60	900	600	348	320	360	400	970	1327	Fig.5-1 Fig.5-2

- Single unit installation

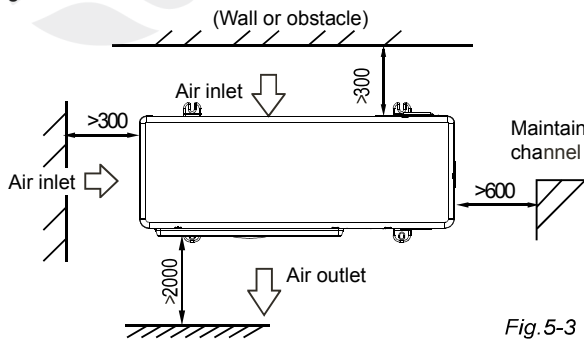

Fig.5-3

- Parallel connect the two units or above

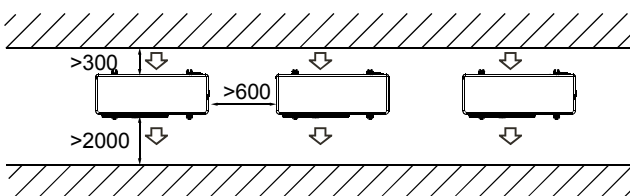

Fig.5-4

- Parallel connect the front with rear sides

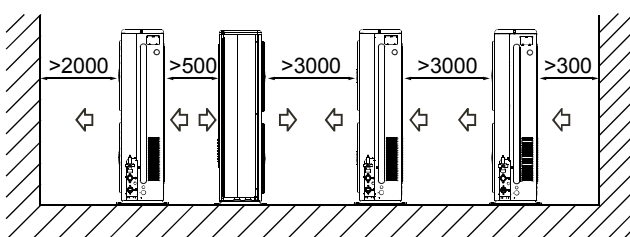

Fig.5-5

5.3 Moving and installation

- Since the gravity center of the unit is not at its physical center, so please be careful when lifting it with a sling.
- Never hold the inlet of the outdoor unit to prevent it from deforming.
- Do not touch the fan with hands or other objects.
- Do not lean it more than 45°, and do not lay it sidelong.
- Make concrete foundation according to the specifications of the outdoor units.(refer to Fig.5-6)
- Fasten the feet of this unit with bolts firmly to prevent it from collapsing in case of earthquake or strong wind. (refer to Fig.5-6)

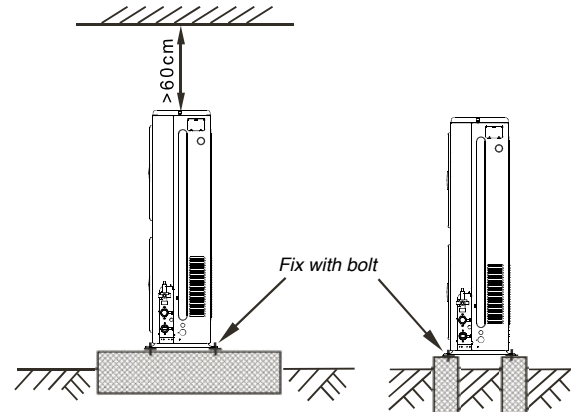

Fig.5-6



NOTE

All the pictures in this manual are for explanation purpose only. They may be slightly different from the air conditioner you purchased(depend on model).The actual shape shall prevail.

5.4 Water Outlet

Four condensed water outlets on the chassis for selection display as the follow figure:

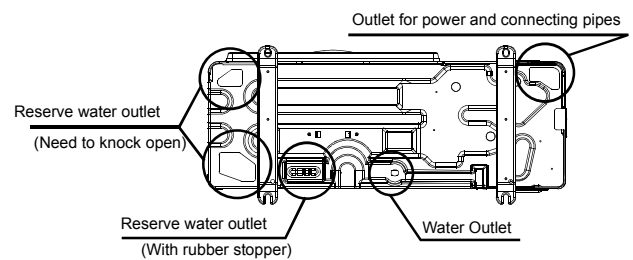

Fig.5-7



CAUTION

While installing the outdoor unit, pay attention to the installation place and the drainage pattern;
if it's installed at the alpine zone, the frozen condensed water will block up the water outlet, please pull out the rubber stopper of the reserve water outlet. If that still fails to satisfy for the water draining, please knock open the other two water outlets, and keep the water can drain in time.
Pay attention to the knock the reserve water outlet from outside to inside, and it will be beyond repair after knocking open, please pay attention to the installation place, lest cause the inconvenience.
Please do the moth proofing for the knocked out hole, to avoid the pest processing into and destroy the components.

6. WATER PIPE INSTALLATION

The choice and installation of components is the responsibility of the installer who should follow good working practice and current legislation. Before connecting the pipes, make sure they do not contain stones, sand, rust, dross or other foreign bodies which might damage the unit. Construction of a bypass is recommended to enable the pipes to be washed through without having to disconnect the unit

(see drain valves). The connection piping should be supported in such a way as to avoid it weighing on the unit. It is recommended that the following devices are installed in the water circuit of the evaporator.

A hydraulic safety valve shall be mounted in water system, which should open constantly.

6.1 Connection drawing of pipeline system

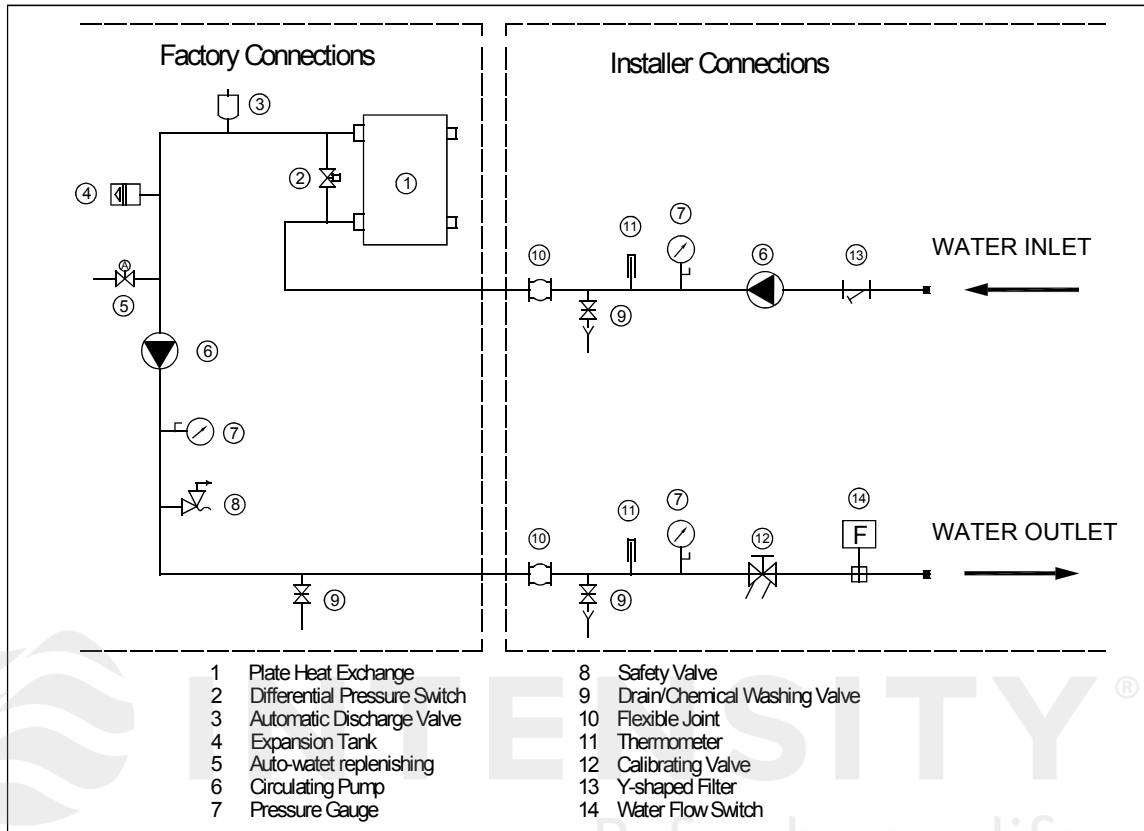

Fig. 6-1

If the installation requires a useful head higher than that obtained by installing a pump assembly and storage tank, it is recommended that an additional pump is installed on the unit. Provided the additional pump installed inside of unit, the pump must be connected close to plate heat exchanger. Provided the pump installed outside of unit, the pump shall be connected at water pipe's outlet. The pump can be easily installed on the unit by removing the pump connection pipe. Connect to terminal PL, PN on the electrical panel.

■ In certain occasion (especially in manufacture cooling process), for conforming the system water content requirement, it's necessary to mount a tank equipping with a cut-off baffle at the system to avoid water short-circuit, Please see the following schemes:

6.3 Minimum chilled water flow

The minimum chilled water flow is shown in the table 6-1

If the system flow is less than the minimum unit flow rate, the evaporator flow can be recirculated, as shown in the diagram.

For minimum chilled water flow rate

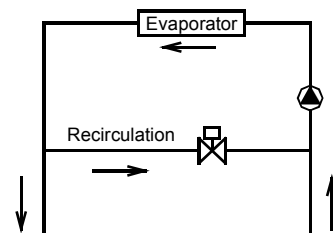

Fig. 6-2



CAUTION

The chillers must be provided with a filling/top-up system connected to the return line and a drain cock in the lowest part of the installation. Installations containing anti-freeze or covered by specific legislation must be fitted with hydraulic disconnectors.



CAUTION

The manufacturer is not liable for obstruction, breakage or noise resulting from the failure to install filters or vibration dampers. Particular types of water used for filling or topping up must be treated with appropriate treatment systems. For reference values, see the table.

6.2 Design of the tank in the system

- kW is the unit for cooling capacity and L is the unit for G water flow in the formula counting the minimum water flow.
- Comfortable type air conditioner
- $G = \text{cooling capacity} \times 2.6L$

6.4 Maximum chilled water flow

The maximum chilled water flow is limited by the permitted pressure drop in the evaporator. It is provided in the table 6-1

If the system flow is more than the maximum unit flow rate, bypass the evaporator as shown in the diagram to obtain a lower evaporator flow rate.

For maximum chilled water flow rate

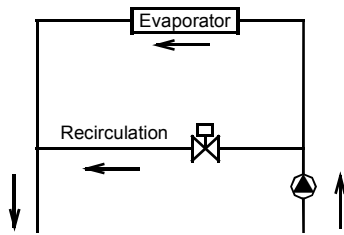

Fig.6-3

6.5 Minimum and Maximum water flow rates

Table 6-1

Model	Item	Water flow rate(m ³ /h)	
		Minimum	Maximum
IMCH-036KC-3		1.54	1.89
IMCH-060KC-3		2.63	3.22

6.6 Water quality control

6.6.1 Water quality control

When industrial water is used as chilled water, little furring may occur; however, well water or river water, used as chilled water, may cause much sediment, such as furring, sand, and so on. Therefore, well water or river water must be filtered and softened in softening water equipment before flowing into chilled water system. If sand and clay settle in the evaporator, circulation of chilled water may be blocked, and thus leading to freezing accidents; if hardness of chilled water is too high, furring may occur easily, and the devices may be corroded. Therefore, the quality of chilled water should be analyzed before being used, such as PH value, conductivity, concentration of chloride ion, concentration of sulfide ion, and so on.

6.6.2 Applicable standard of water quality for the unit

Table 6-2

PH value	6 j 8
Total hardness	<50ppm
Conductivity	<200μV/cm(25°C)
Sulfide ion	No
Chloride ion	<50ppm
Ammonia ion	No
Sulfate ion	<50ppm
Silicon	<30ppm
Iron content	<0.3ppm
Sodium ion	No requirement
Calcium ion	<50ppm

6.7 Filling the installation

- Before filling,check that the installation drain cock is closed.
- Open all installation and terminal air vents.
- Open the gate valves.
- Begin filling,slowly opening the water filling cock outside the unit.
- When water begins to leak out of the terminal air vent valves, close them and continue filling until the pressure gauge indicates a pressure of 1.5 bars.

6.8 Emptying the installation

- Before emptying,place the mains switch in the "off " position.
- Make sure the installation fill/top-up water cock is closed.
- Open the drain cock outside the unit and all the installation and terminal air vent valves.

6.9 Size and position of connections

Table 6-3

Model	36/60 Btus
A (mm)	300
B (mm)	195
C (mm)	155
D (mm)	105
E (mm)	68
F (mm)	105
Water inlet/outlet (Ø)	R5/4
Auto-water replenishing (Ø)	G1/2
Security discharge (Ø)	G1/2

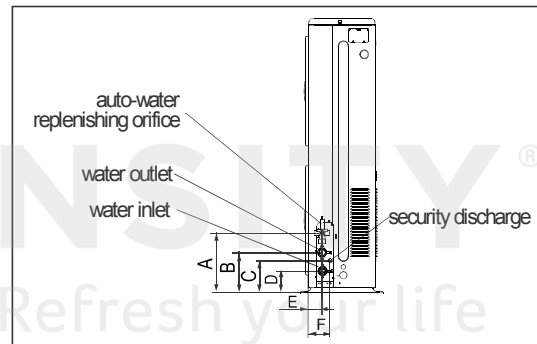

Fig.6-4



CAUTION

The installation must be filled to a pressure of between 1 and 2 bars.

It is recommended that this operation be repeated after the unit has been operating for a number of hours.The pressure of the installation should be checked regularly and if it drops below 1 bar,the water content should be topped-up.

Check the hydraulic tightness of joints.



CAUTION

An all-pole disconnection device which has at least 3mm separation distance in all pole and a residual current device (RCD) with the rating of above 10mA shall be incorporated in the fixed wiring according to the national rule the appliance shall be installed in accordance with national wiring regulations.



CAUTION

If the fluid in the circuit contains anti-freeze,it should not be allowed to drain freely as it is pollutant.It should be collected for possible reuse.When draining after heat pump operation, take care as the water may be hot (up to 50°).

6.10 Basic requirements of connection of chilled water pipes



CAUTION

After the unit is in place, chilled water pipes can be laid.

The relevant installation regulations should be abided with when conducting connection of water pipes.

The pipelines should be free of any impurity, and all chilled water pipes must conform to local rules and regulations of pipeline engineering.

■ Connection requirements of chilled water pipes

a. All chilled water pipelines should be thoroughly flushed, to be free of any impurity, before the unit is operated. Any impurity should not be flushed to or into the heat exchanger.

b. Water must enter the heat exchanger through the inlet, otherwise the performance of the unit will decline.

c. The pump installed in the water pipeline system should be equipped with starter. The pump will directly press water into the heat exchanger of the water system.

d. The pipes and their ports must be independently supported but should not be supported on the unit.

e. The pipes and their ports of the heat exchanger should be easy to disassemble for operation and cleaning, as well as inspection of port pipes of the evaporator.

f. The evaporator should be provided with a filter with more than 40 meshes per inch at site. The filter should be installed near to the inlet port as much as possible, and be under heat preservation.

g. The flexible ports should be adopted between the interface of the heat exchanger and on-site pipeline, to reduce transfer of vibration to the building.

h. To facilitate maintenance, the inlet and outlet pipes should be provided with thermometer or manometer. The unit is not equipped with pressure and temperature instruments, so they need to be purchased by the user.

i. All low positions of the water system should be provided with drainage ports, to drain water in the evaporator and the system completely; and all high positions should be supplied with discharge valves, to facilitate expelling air from the pipeline. The discharge valves and drainage ports should not be under heat preservation, to facilitate maintenance.

j. All possible water pipes in the system to be chilled should be under heat preservation, including inlet pipes and flanges of the heat exchanger.

k. The outdoor chilled water pipelines should be wrapped with an auxiliary heating belt for heat preservation, and the material of the auxiliary heat belt should be PE, EDPM, etc., with thickness of 20mm, to prevent the pipelines from freezing and thus cracking under low temperature. The power supply of the heating belt should be equipped with an independent fuse.

l. When the ambient temperature is lower than 2°C, and the unit will be not used for a long time, water inside the unit should be drained. If the unit is not drained in winter, its power supply should not be cut off, and the fan coils in the water system must be provided with three-way valves, to ensure smooth circulation of the water system when the anti-freezing pump is started up in winter.

m. The common outlet pipelines of combined units should be provided with mixing water temperature sensor.



WARNING

For the water pipeline network including filters and heat exchangers, dreg or dirt may seriously damages the heat exchangers and water pipes.

The installation persons or the users must ensure the quality of chilled water, and de-icing salt mixtures and air should be excluded from the water system, since they may oxidize and corrode steel parts inside the heat exchanger.

7. RECOMMENDED OPERATING AREA

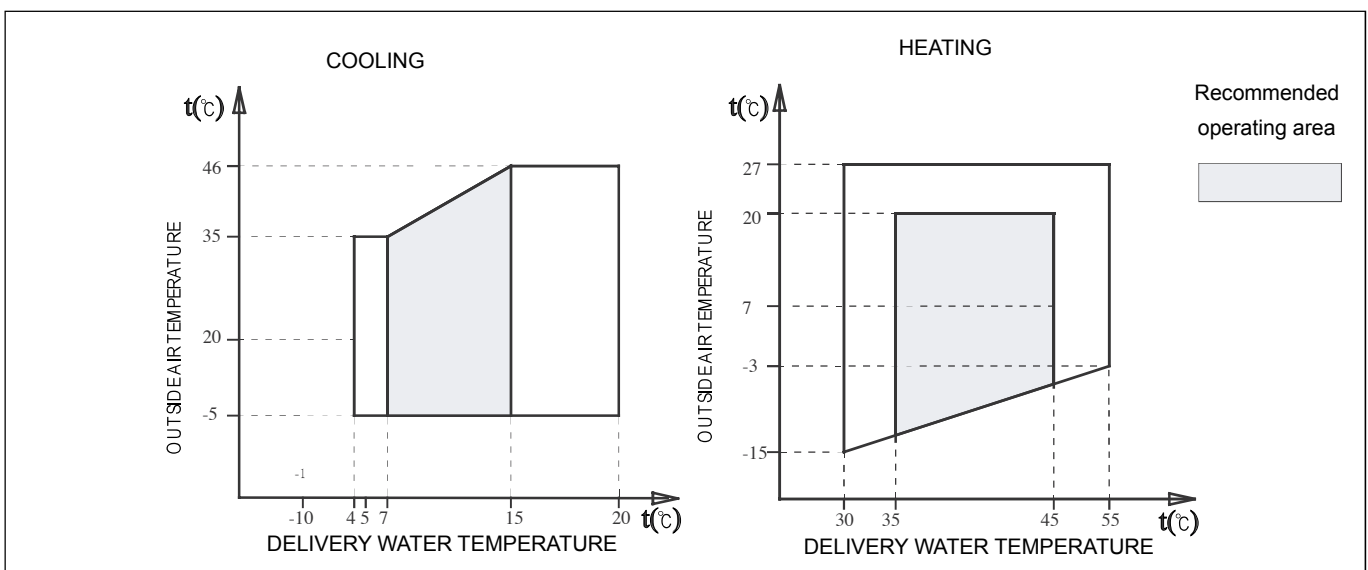

Fig. 7-1

Thermal head min.- max.	4-6
Water circuit pressure (bars)	1-3
Max.storage temperature	55

7.1 Ethylene glycol solutions

Water and ethylene glycol solutions used as a thermal vector in the place of water reduce the performance vector in the place of water reduce the performance values given in the following table.

	Freezing point (°C)					
	0	-5	-10	-15	-20	-25
Percentage of ethylene glycol in weight						
	0	12%	20%	28%	35%	40%
cPf	1	0.98	0.97	0.965	0.96	0.955
cQ	1	1.02	1.04	1.075	1.11	1.14
cdp	1	1.07	1.11	1.18	1.22	1.24

cPf: correction factor refrigerating capacity

cQ: correction factor flow rate

cdp: correction factor pressure drop



CAUTION

During winter leaving the unit unused, please drain water out completely from unit if no antifreeze were charged into pipeline, or keep power on(at standby or off status) and ensure that water is contained inside of unit.

When ambient temperature lower 5 running cooling mode must be charged antifreeze. Refer to upper parameters for the charged volume.

7.2 Fouling factors

The performance data given refer to conditions with clean evaporator plates (fouling factor=1).For different fouling factors,multiply the figures in the performance tables by the coefficient given in the following table.

Fouling factors (m ² °C/W)	Evaporator		
	f1	fk1	fx1
4.4 x 10 ⁻⁵	-	-	-
0.86 x 10 ⁻⁴	0.96	0.99	0.99
1.72 x 10 ⁻⁴	0.93	0.98	0.98

f1: capacity correction factor

fk1: compressor power input correction factor

fx1: total power input correction factor

8. HYDRAULIC DATA

8.1 Useful pump head curves (36/60 BTUS/h)

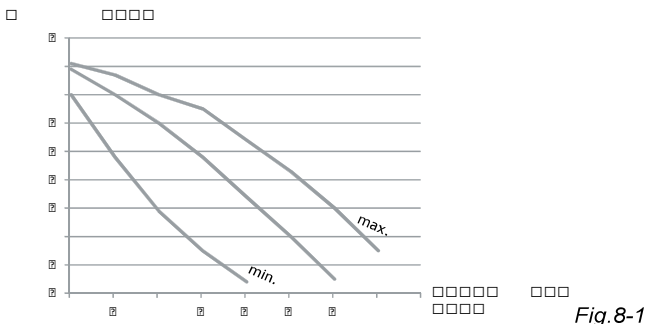

Fig. 8-1

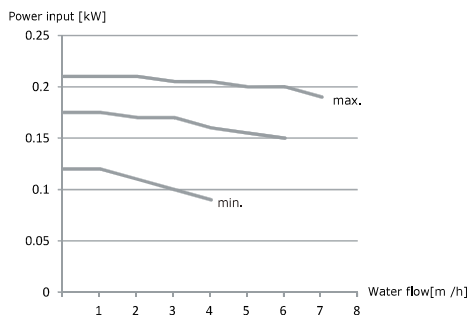

Fig. 8-2

9. ELECTRICAL CONNETIONS

The unitary minichillers leave the factory already wired, and require the installation of an omnipolar thermal overload switch, a lockable mains disconnecting switch for the connection to the mains power supply, and the connection of the flow switch to the corresponding terminals. All the above operations must be carried out by qualified personnel in compliance with the legislation in force.

For all electrical work, refer to the electrical wiring diagrams in this manual. You are also recommended to check:

-that the characteristics of the mains electricity supply are adequate for the absorptions indicated in the electrical characteristics table below, also bearing in mind the possible use of other equipment at the same time.



CAUTION

Power to the unit must be turned on only after installation work (hydraulic and electrical) has been completed.

All electrical connections must be carried out by qualified personnel in accordance with legislation in force in the country concerned.

Respect instructions for connecting phase, neutral and earth conductors. The power line should be fitted upstream with a suitable device to protect against short-circuits and leakage to earth, isolating the installation from other equipment.



CAUTION

Voltage must be within a tolerance of $\pm 10\%$ of the rated power supply voltage for the unit (for three phase units, the unbalance between the phases must not exceed 3%). If these parameters are not respected, contact the electricity supply company. For electrical connections, use double insulation cable in conformity with current legislation in the country concerned.

An omnipolar thermal overload switch and a lockable mains disconnecting switch, in compliance with the CEI-EN standards (contact opening of at least 3mm), with adequate switching and residual current protection capacity based on the electrical data table shown below, must be installed as near as possible to the appliance.



CAUTION

The devices on the unit must be lockable.

An efficient earth connection is obligatory. Failure to earth the appliance absolves the manufacturer of all liability for damage.



CAUTION

Do not use water pipes to earth the unit.

9.1 The Specification of Power

Table 9-1

MODEL		IMCH-036KC-3	IMCH-060KC-3
POWER	PHASE	1-PHASE	1-PHASE
	FREQUENCY AND VOLT	208/230V~, 60Hz	208/230V~, 60Hz
CIRCUIT BREAKER/FUSE (A)		40/35	40/35
POWER WIRING(mm ²)		3x4.0	3x6.0
GROUND WIRING(mm ²)		4.0	4.0



CAUTION

The power cord type designation is H07RN-F.

Connecting cable between indoor unit and outdoor unit shall be approved polychloroprene sheathed flexible cord, type designation H07RN-F or heavier cord.

The means for disconnection from a power supply shall be incorporated in the fixed wiring and have an air gap.

9.2 Electrical connections

9.2.1 To complete the electrical connections

- Remove the inspection panel by unscrewing the five screws.

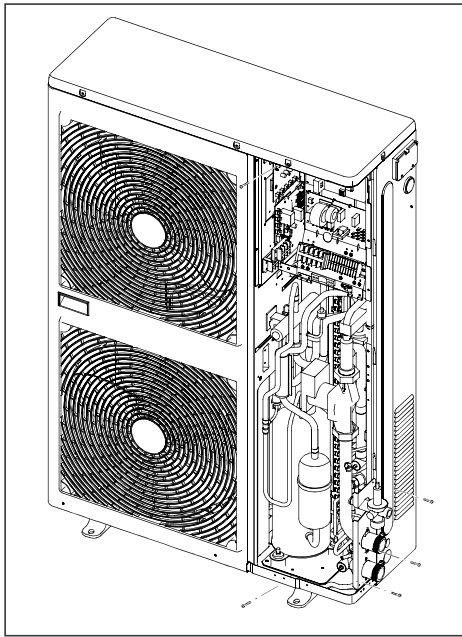

Fig. 9-1

- Use grommet A for the electrical power cable and grommet B for the other external wires.

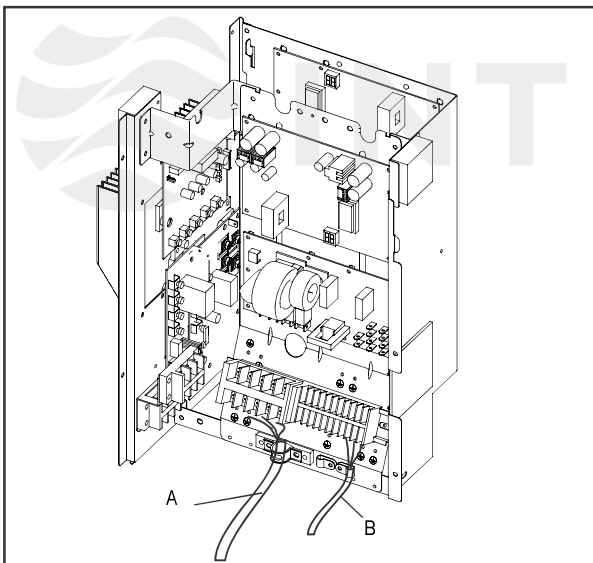

Fig. 9-2

9.2.2 Customer connection terminal

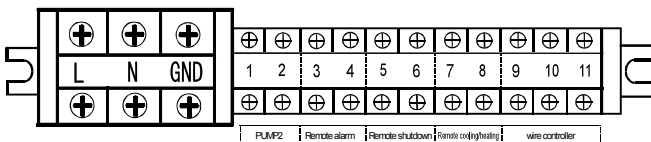
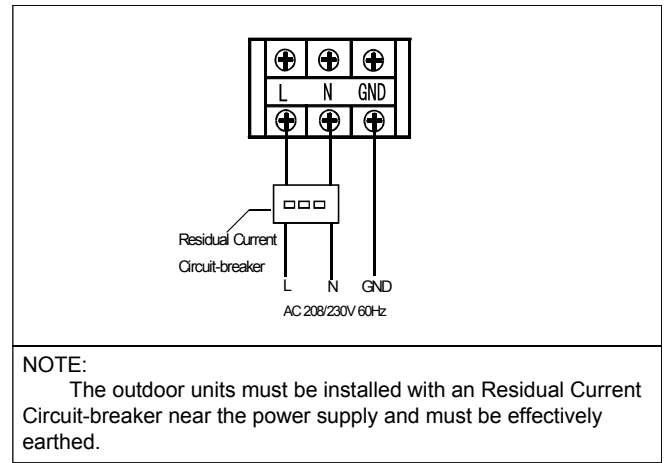

Fig. 9-3

9.2.3 Electrical power connections



NOTE:

The outdoor units must be installed with an Residual Current Circuit-breaker near the power supply and must be effectively earthed.

Fig. 9-4

9.2.4 Auxiliary function connections

- Additional pump

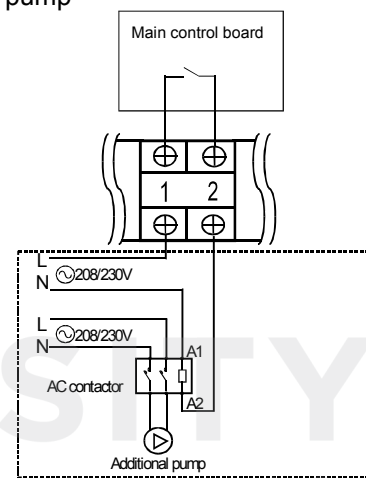

Fig. 9-5

"PUMP2" terminal only provides passive switching signal. Additional water pump must be controlled by the AC contactor.

- Remote alarm

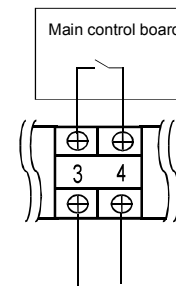

Fig. 9-6

"Remote alarm" terminal only provides passive switching signal. Current passing through the terminal interface should less than 1.5A, otherwise please use AC contactor to control load indirectly.

- Remote shutdown

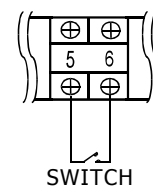

Fig. 9-7

If switch is closed, the unit will be stopped forcibly. Under this circumstance, anti-frozen protection and other protection functions are still effective. If switch breaks, unit can run normally according settings.

■ Remote cooling/heating

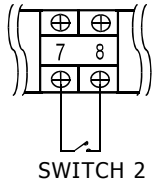

Fig.9-8

If switch2 is closed, the unit will shift to heating mode forcibly;
If switch2 breaks the unit will shift to cooling mode forcibly.



NOTE

Remote shutdown and Remote cooling/heating is optional function.
Factory default has no remote cooling/heating.
When the remote control and wire controller used at the same time, the unit will carry out the last command of arbitrary terminal.
Remote shutdown has the highest priority. In the status of remote shutdown, other controllers can't start the unit.

9.3 Checking and starting up the unit

- Restarting after shutting down for long periods.
The chiller must be started up for the first time by the Technical Service. Before starting up the chillers, make sure that:
- All safety conditions have been respected;
 - The chiller is adequately fixed to the surface it rests on;
 - Functional distances have been respected;
 - Hydraulic connections have been carried out as indicated in the instruction manual;
 - The water circuit is filled and vented. When draining after heat pump operation, take care as the water may be hot;
 - The water circuit valves are open;
 - Electrical connections have been carried out correctly;
 - Voltage is within a tolerance of 10% of the rated voltage for the unit;
 - The unit is correctly earthed;
 - All electrical and hydraulic connections are tight and have been completed correctly.

■ Wire controller

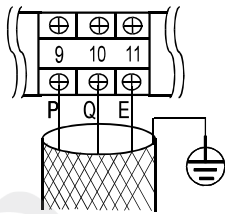

Fig.9-9

The wire controller is optional.
Please use 3-core shielded wire to connect the wire controller and the shielding layer must be grounded.
When connecting wire controller, host unit control panel is mainly used for display which can carry out parameter inquiry such as inquiry and checking, and can't be used to set mode and temperature.

10. THE HOST UNIT CONTROLLER ELUCIDATION

10.1 To access the control panel, open the door

- remove the screw 1 and screw 2;
- lift the door 3.

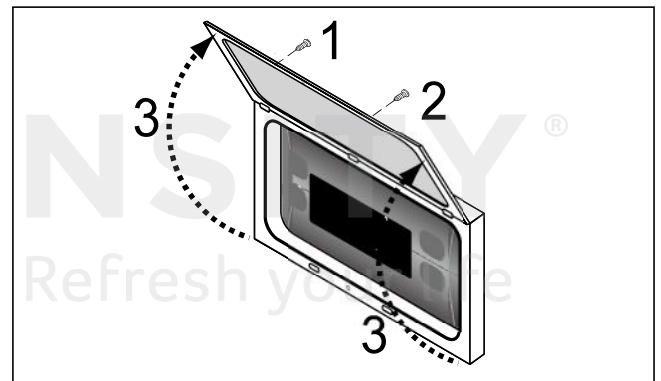

Fig.10-1

10.2 Activating and deactivating the unit

10.2.1 Icon Description

The front panel of the device functions as the user interface and is used to perform all operations relating to the device.

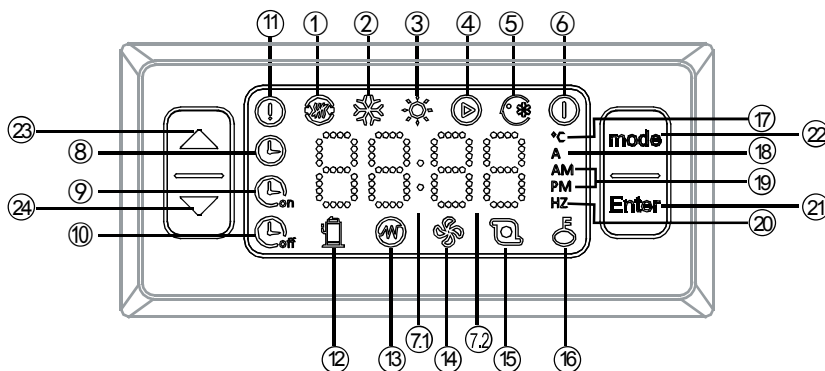

Fig.10-2

NO.	Icon	Description
①		Outside heat source running icon(Reserved)
②		Cooling mode icon This icon will be constantly light when customers choose cooling mode.
③		Heating mode icon This icon will be constantly light when customers choose heating mode.
④		Water pump mode icon This icon will be constantly light when customers choose water pump mode.
⑤		Force cooling icon This icon will be constantly light when customers choose force cooling mode.
⑥		Power off icon This icon will be constantly light when customers choose Power off mode.
⑦①	88:88	Clock icon, the middle ":" flicker once every 1s. It will display time when customers set the timer.
⑦②	88	The last 2 digits of the nixie tube "88" icon. If "88" is constantly light, it will display the current inlet water temperature. Its unit is °C . When customers do water temperature set, icon will display the set water temperature. When checking, "88" will display the result of checking. When water heating is broken down or in protection, "88" display the error code and protection code.
⑧		Clock icon It will display when finish setting the clock and be extinguished when the clock setting work is done.
⑨		Timing on function icon will flicker when setting timing on. The icon will be constantly light when finish setting.
⑩		Timing off function icon will flicker when setting timing off. The icon will be constantly light when finish setting.
⑪		Breakdown light icon When the unit is broken down or under protection, this icon will flicker and will be extinguished when malfunction and protection are eliminated.
⑫		Compressor booting indicator icon When booting the compressor, this icon will be constantly light. It will be extinguished when the compressor is shut down
⑬		E-heater booting indicator icon ~Reserved~ When booting the external E-heater, this icon will be constantly light. It will be extinguished when the external E-heater is shut down.
⑭		Fan booting indicator icon When booting the fan, this icon will be constantly light. It will be extinguished when the fan is shut down.
⑮		Water pump booting indicator icon When booting the water pump, this icon will be constantly light. It will be extinguished when the water pump is shut down.
⑯		Key freezing icon When freezing the keys, this icon will be constantly light. It will be extinguished when unfreezing keys.
⑰		Temperature unit icon When the control panel displays temperature, this icon will be constantly light.
⑱		Current unit icon When the control panel displays current, this icon will be constantly light.
⑲	AM PM	Time format icon The unit is 12-hour format. "AM" will be constantly light when it is forenoon. "PM" will be constantly light when it is afternoon
⑳	HZ	Frequency unit icon It will be constantly light when the control panel displays frequency of the compressor.
㉑		ON/OFF and OK button 1.Press "" to confirm the former operation when finishing the setting work. 2.Long press "" for 3S will recovers to factory default mode.
㉒		Mode choice function/Function choice/Back function button 1.Mode choice function. Choose operation mode. 2.Function choice. Long press it for 3s to enter function setting in the main interface.(Clock setting, Timing on and timing off setting) 3.Back to the previous menu. Long press it for 3s to back to previous menu in the function setting interface. Top menu is the main interface.
㉓		Up 1.(Value increase) 2.Forward to the previous interface.
㉔		Down 1.(Value decrease) 2.Backward to the next interface.

10.2.2 Control panel operation description

1. ON/OFF

The first time to powered on the unit, Operation panel displays "OFF". Long press "**Enter**" for 3s, to unlock "OFF" status and enter into standby status.
Power on: In the standby status, press "**mode**" to enter mode choice function. Press "**mode**" circularly to choose one kind of "power on" mode, the mode icon will flicker at the moment. Press "**Enter**" to confirm the power on mode. The unit will run as the chosen mode when the mode icon will be constantly light.
Power off: Press "**mode**" in the main interface to enter mode choice function and the icon which indicate the current mode will flicker. Press "**mode**" circularly to choose power off mode, "**Off**" will flicker at this moment. Press "**Enter**" button to confirm the power off mode. By this time, "**Off**" will be constantly light and the unit stops.

2. Mode choice and temperature settings

Press "**mode**" in the main interface to enter mode choice function. The "Mode" icon will flicker. Click "**mode**" circularly to choose a mode. The circulating order is "Cooling mode" → "Heating mode" → "Water pump mode" → "Power off mode" →

"Cooling mode". The chosen mode will flicker.

Press "**▲**" or "**▼**" to increase/decrease the temperature in the chosen mode.

Press "**Enter**" to confirm power off mode and the set temperature. Mode icon will be constantly light and the unit will run as the chosen mode.

Press "**▲**" or "**▼**" in the main interface to increase/decrease the temperature in the chosen mode.

3. Clock setting

Long press "**mode**" for 3s to enter function interface. "**Clock**" clock icon will flicker. Press "**Enter**" to enter clock setting function. "**Clock**" icon will be constantly light and the first 2 digits on nixie tube will flicker. Press "**▲**" or "**▼**" to set minute. Press "**Clock**" when finish setting and "**Enter**" will be extinguished.

4. Timing setting

1. Timing on setting

① Long press "**mode**" for 3s to enter function interface. "**Clock**" clock icon will flicker. Press "**mode**" again to enter timing on function. "**On**" will flicker and press "**Enter**" to enter timing on setting.

② At this moment, last 2 digits of the nixie tube display "01" which means the first group setting begins. Press "**Enter**" to the next step.

③ By this time, mode icon will flicker and press "**mode**" to choose timing on mode. Press "**Enter**" to confirm your choice and go to the next step.

④ By this time, the last 2 digits of the nixie tube will flicker and press "**▲**" or "**▼**" to adjust temperature and set the temperature of the inlet water. Press "**Enter**" to confirm and move to the next step.

⑤ By this time, the first 2 digits of the nixie tube will flicker and press "**▲**" or "**▼**" to adjust time of timing on. Press "**mode**" to confirm and switch to minute setting automatically. The last 2 digits of the nixie tube will flicker and press "**▲**" or "**▼**" to adjust minute setting of timing on. (minimal unit of minute adjustment: 15 minutes).

⑥ Press "**Enter**" to confirm. The first group setting is finished and "**On**" will be constantly light. When processing the second timing setting, repeat the 1-2 operation above. When the nixie tube displays "01" and flicker, press "**▲**" or "**▼**" to choose the timing on group. When the nixie tube displays "02" which means setting timing on function of the second group.

Refers the timing on setting operation of group 1 to set that of group 2.

Long press "**mode**" for 3s to return to the previous interface to reset the parameter during setting clock timing.

2. Timing off setting

① Long press "**mode**" for 3s in the main interface to enter function interface. Press "**mode**" circularly to enter timing off function. "**Off**" will flicker and press "**Off**" to enter timing off setting.

② At this moment, the last 2 digits of the nixie tube display "01" which means the first group setting begins. Press "**Enter**" to the next step.

③ By this time, the first 2 digits of the nixie tube will flicker and press "**▲**" or "**▼**" to adjust time of timing off. Press "**mode**" to confirm and switch to minute setting automatically. The last 2 digits of the nixie tube will flicker and press "**▲**" or "**▼**" to adjust minute setting of timing off. Press "**Enter**" to confirm. The first group setting is finished and "**Off**" will be constantly light.

④ When processing timing setting of group 2, repeat the 1-2 operation above. When the nixie tube displays "01" and flicker, press "**▲**" or "**▼**" to choose the timing off group. When the nixie tube displays "02" which means setting timing off function of the second group.

Refers the timing off setting operation of group 1 to set that of group 2.

3. Cancel all timing on/off settings

Long press "**mode**" for 3s to enter function interface. "**Clock**" clock icon will flicker and press "**mode**" to choose the timing function. "**On**" and "**Off**" flicker simultaneously means choosing to cancel all timing functions.

Press "**Enter**" to cancel timing settings. "**On**" and "**Off**" both will be extinguished.

10.2.3 Functions of combination key

1. Force cooling

Press "**▼**" and "**mode**" simultaneously for 3s in the main interface to enter into force cooling mode. The force cooling mode icon will be constantly light.

Press "**▼**" button and "**mode**" button simultaneously for 3s to quit force cooling mode. The unit will enter power off mode automatically when quitting force cooling mode.

2. Parameter query function

① To enter parameter query function.

Press "**▲**" and "**▼**" simultaneously for 3s to enter into the interface of parameter query function. At this moment, first 2 digits of the nixie tube **88-88** will display sequence number and the last 2 digits is specific parameters.

Press "**▲**" or "**▼**" to query the relative parameters. See query orders in Table 10-1.

② Quit parameter query function

If there's no operation in 20s when enter the parameter query, it will quit automatically and return to the main interface.

Press "**▲**" and "**▼**" simultaneously to quit parameter query manually.

Table.10-1 Query orders

No.	Content	Remark
1	Frequency	Display operating frequency when the unit is in cooling mode and heating mode.
2	Mode	0-Power off '1-water pump '2-cooling '3-heating '4-force cooling '5-force heating
3	Wind speed level	0-Power off (1-7)
4	Total capacity requirements	Capacity before revised(Force cooling displays 5)
5	Capacity requirements after revised	Capacity after revised (Force cooling displays 5)
6	Temp. set	Cooling/heating temp. set
7	T3	Condenser temperature sensor
8	T4	Outdoor ambient temperature sensor
9	Tp	Comp. Discharge temperature sensor
10	Tin	Inlet water temperature sensor of plate heat exchanger
11	Tout	Outlet water temperature sensor of plate heat exchanger
12	Tb1	Plate heat exchanger anti-freezing temperature sensor 1
13	Tb2	Plate heat exchanger anti-freezing temperature sensor 2
14	T6	Radiator surface temperature(reserved)
15	Unit operation current	Unit operation current
16	Power supply voltage AD value	Power supply voltage AD value
17	Opening of EXV	Step number *8
18	Model	(Operation panel has no such function)
19	Version number	(Operation panel has no such function)
20	Err1	
21	Err2	(PCB has no such function)
22	Err3	(PCB has no such function)

3.Auto-lock(unlock) function

If don't operate the controller in 60s, the keyboard will lock automatically. Press "**mode**" and "**Enter**" simultaneously for 3s to unlock.

4.Factory Reset:

In main interface, long press "ENTER" for 3s, the unit will close and recovers to factory default mode.
Display panel will display"OFF" °

5.Error code and protection code shooting table:

E9	EEPROM malfunction
CP	Anti-idling protection of water pump
CL	Low temperature protection in heating mode
H0	Communication malfunction between the main controlling chip and IPDU
E4	T3& T4 temperature sensor malfunction
E5	Voltage protection
E6	DC fan motor malfunction
EA	5-minute error for heating mode fan in area A
Eb	Two times of E6 protection in 10 minutes(Recover when powering off)
C0	Tin temperature sensor malfunction
C1	Tout temperature sensor malfunction
F7	Tb1 temperature sensor malfunction
F8	Tb2 temperature sensor malfunction
PL	Radiator high temperature protection
P1	High pressure protection
P2	Low pressure protection
P3	Outdoor units current protection

P4	Compressor discharge temperature protection
P5	Condenser high temperature protection
P6	IPM mode protection
P8	Typhoon protection
Pb	Outdoor units anti-freezing protection
C8	Flow switch malfunction
CH	High temperature protection in heating mode
dF	Defrosting
d0	Oil return of compressor
d8	Remote control

10.3 Operating characteristics

■ Set point in cooling

(factory set) = 12°C,Hysteresis = 3°C.

The compressor starts with water temperatures above 12°C.
The compressor shuts down with water temperatures of less than 9°C.

■ Set point in heating

(factory set) = 40°C,hysteresis = 4°C.

The compressor starts with water temperatures below 38°C.
The compressor shuts down with water temperatures above 42°C.

In the event of a temporary power failure,when power returns, the mode set previously will be retained in the memory.

■ Compressor start up delay

Two functions prevent the compressor from starting up too frequently.

-Minimum time since last start-up 300 seconds.

■ Pump

The electronic board includes a pump control output. The pump starts when the assembly is powered up and at least 285 seconds before the compressor starts up and stops 120 seconds after the assembly shuts down.

After the first 120 seconds of pump operation when the water flow is at full speed, the water flow alarm functions are activated (differential pressure switch and flow switch).

With a pump connected to terminals PL and PN on the installer terminal board.

■ Fan speed control

For correct operation of the unit with different outside temperatures, the microprocessor controls the fan speed based on the pressure reading from the pressure probe, thus enabling heat exchange to be increased and/or decreased, maintaining the condensing or evaporation temperature practically constant.

The fan functions independently of the compressor.

■ Frost prevention alarm

To prevent the water freezing and damaging the plate heat exchanger, the microprocessor shuts down the compressor if the temperature measured by the heat exchanger outlet temperature sensor is less than 3°C.

The frost prevention temperature set point can be modified by an authorised service centre only and only after verifying that the water circuit contains antifreeze.

Tripping of this alarm shuts down the compressor but not the pump, which remains active.

To reset normal functions, the outlet water temperature must rise to more than +15°C. Reset is manual.

■ Water flow alarm

The microprocessor provides for management of a water flow alarm controlled by a water flow switch fitted as standard on the appliance and a flow switch to be installed on the water delivery piping.

This safety device may trip after the first 120 seconds of pump operation when the water flow is up to speed.

Tripping of this alarm shuts down the compressor but not the pump, which remains active.

To reset normal functions, the alarm contact must be deactivated for at least 15 seconds.

When condenser temperature over than 62°C, system will shut down, but not returns to normal operation until the condenser temperature decreased less than 52°C.

10.4 Shutting down for long periods

If it is previewed not to use the machine for long periods After deactivating the chiller:

- Make sure the model is in the Power off model "  ", or alternatively disconnect the unit from the power supply.
- Make sure the remote control switch is closed (if present) .
- Close the water valves.



CAUTION

If there is a possibility that the outside temperature may drop below zero, there is the risk of freezing. The water circuit MUST BE EMPTIED AND SHUT OFF POWER (when draining after heat pump operation take care as the water may be hot) or antifreeze must be added in the proportion recommended by the manufacturer.

11. MAIN PARAMETERS

Model		IMCH-036KC-3	IMCH-060KC-3
Cooling	Capacity (kW)	10.0(2.9~10.5)	17.0(3.8~18.0)
	Rated input (W)	2950	5850
	Rated current (A)	12.8	25.4
Heating	Capacity (kW)	11.0(3.2~12.0)	18.0(4.0~19.0)
	Rated input (W)	3140	5780
	Rated current (A)	13.6	25.6
Max. input consumption (W)		4800	6700
Max. input current (A)		25.0	30
Power supply		208/230V~ 60Hz	
Refrigerant	Type	R410A	
	Chargeing volume (kg)	2.8	3.4
N.W. of the unit (kg)		110	112
Outline dimension	W×H×D (mm)	970×1327×400	
Packing dimension	W×H×D (mm)	1082×1456×435	
Ambient temp (°C)		Cooling: 5°C~46°C; Heating: -15°C~27°C	
Water inlet setting temp. range(°C)		Cooling: 10°C~20°C; Heating mode: 35°C~50°C	
MAX. WATER PRESSURE		1.0MPa	
Notes: the above data is measured base on the following working condition. Refrigeration mode under nominal working condition: Condenser air in 35 . Evaporator water in/out 12/7 . Heating mode under nominal working condition: Evaporator air in 7 85% R.H., Condenser water in/out 40/45 .			